

CS 6530: Advanced Database Systems Fall 2022

Lecture 12

Log-Structured Merge (LSM) Trees

Prashant Pandey

prashant.pandey@utah.edu

How Should I Organize My Stuff (Data)?

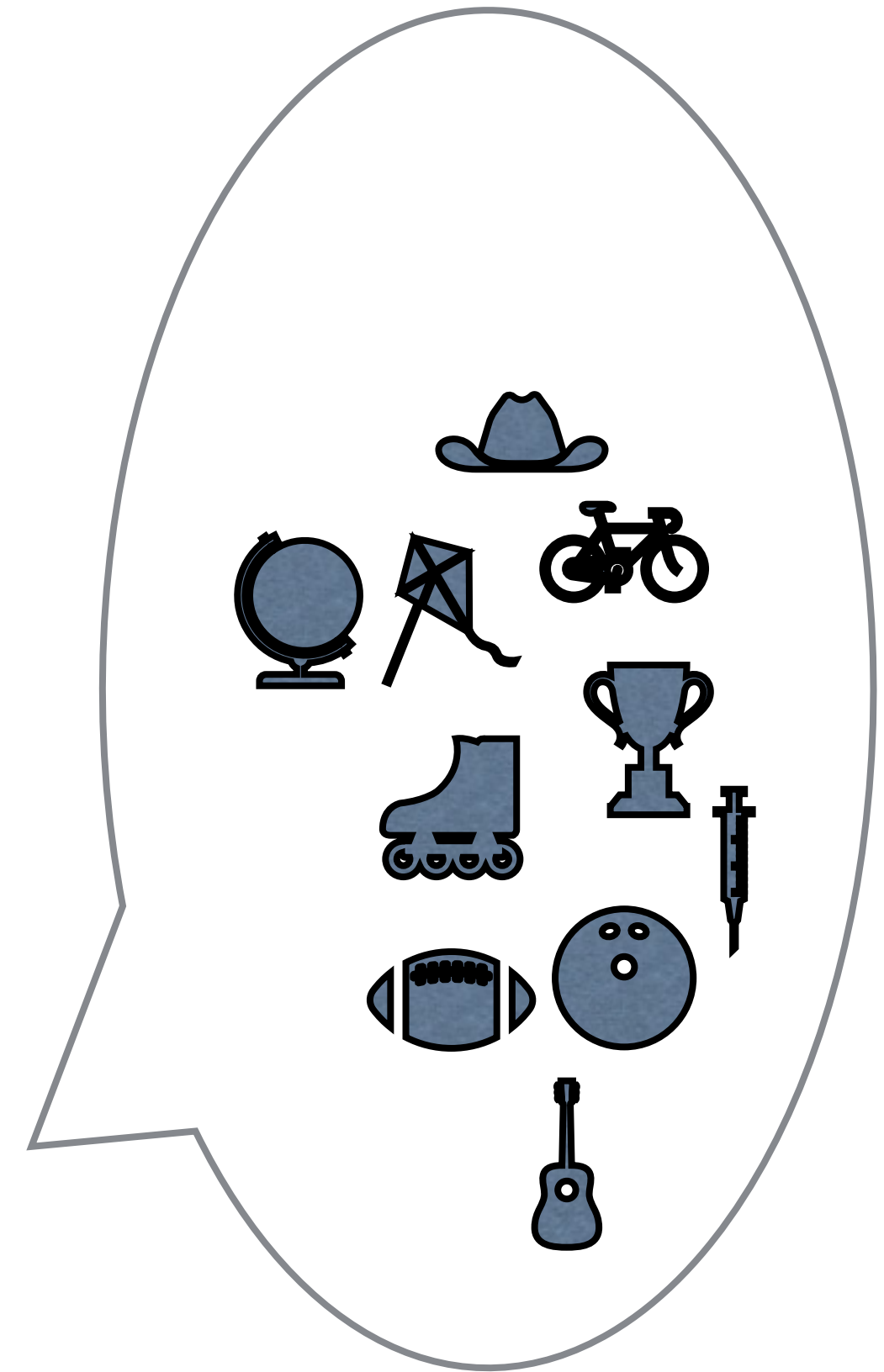
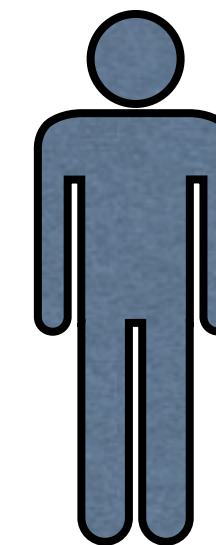
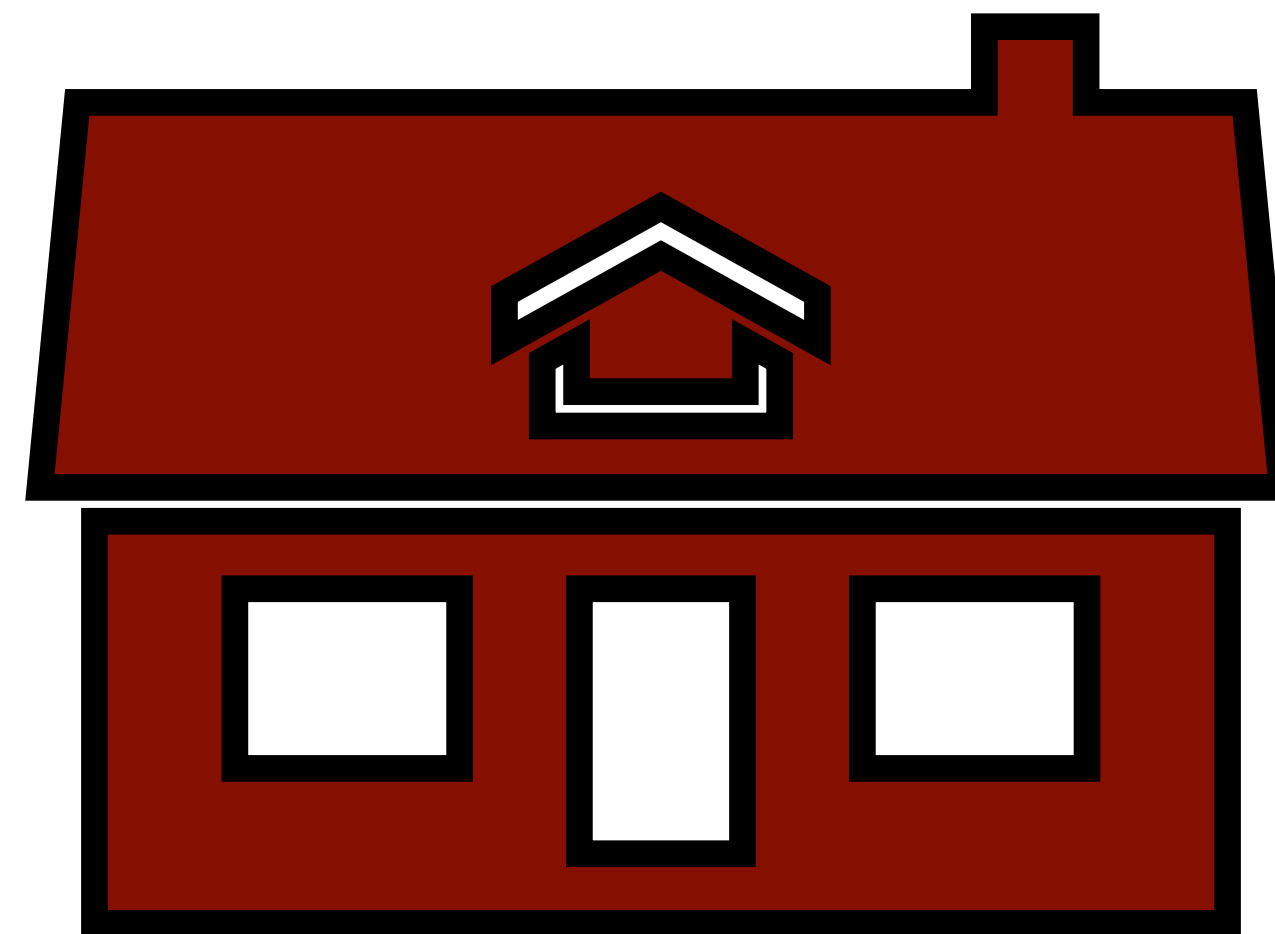

How Should I Organize My Data?

Different people approach the problem differently...

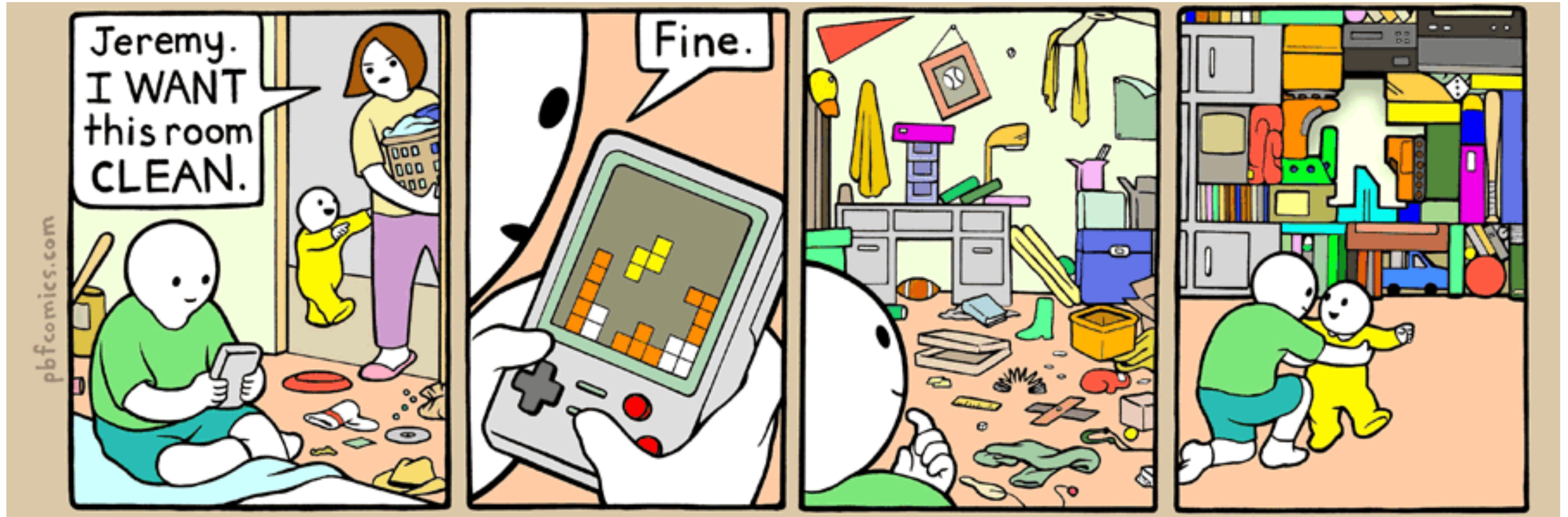

[<https://pbcomics.com/comics/game-boy/>]

How Should I Organize My Data?

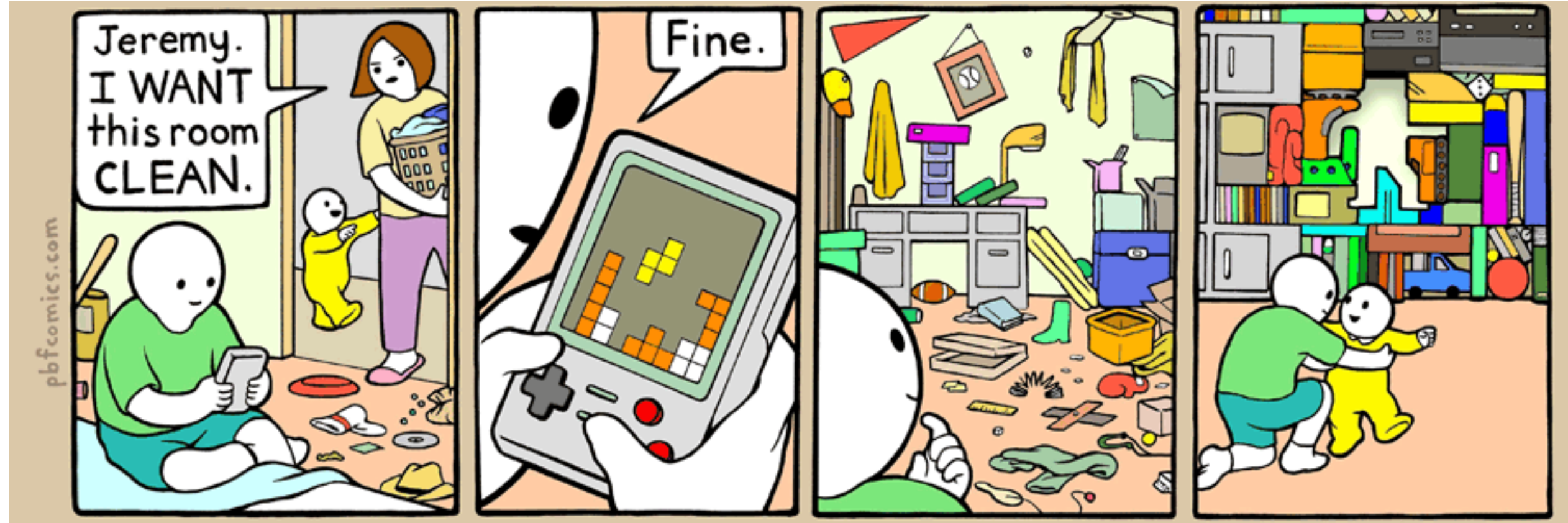

“Logging”

“Indexing”

How Should I Organize My Data?

	Logging	Indexing
Inserting	Append at end of log	Insert at leaf (traverse root-to-leaf path)
Searching	Scan through entire log	Locate in leaf (traverse root-to-leaf path)

How Should I Organize My Data?



Are We Forced to Choose?

It appears we have a tradeoff between insertion and searching

- **B-trees have**
 - ▶ fast searches: $O(\log_B N)$ is the optimal search cost
 - ▶ slow inserts
- **Logging has**
 - ▶ fast insertions
 - ▶ slow searches: cannot get worse than exhaustive scan

Goal: Data Structural Search for Optimality

B-tree searches are optimal

B-tree updates are not

- We want a data structure with inserts that beat B-tree inserts without sacrificing on queries

> This is the promise of **write-optimization**

Log-Structured Merge Trees

Data structure proposed by O'Neil, Cheng, and Gawlick in 1996

- Uses write-optimized techniques to significantly speed up inserts

Hundreds of papers on LSM-trees (innovating and using)

To get some intuition for the data structure, let's break it down

Log-structured • Merge • Tree

Log-Structured Merge Trees

Log-structured

- All data is written sequentially, regardless of logical ordering

Merge • Tree

Log-Structured Merge Trees

Log-structured

- All data is written sequentially, regardless of logical ordering

Merge

- As data evolves, sequentially written runs of key-value pairs are merged
 - ▶ Runs of data are indexed for efficient lookup
 - ▶ Merges happen only after much new data is accumulated

Tree

Log-Structured Merge Trees

Log-structured

- All data is written sequentially, regardless of logical ordering

Merge

- As data evolves, sequentially written runs of key-value pairs are merged
 - ▶ Runs of data are indexed for efficient lookup
 - ▶ Merges happen only after much new data is accumulated

Tree

- The hierarchy of key-value pair runs form a tree
 - ▶ Searches start at the root, progress downwards

Log-Structured Merge Trees

Start with [O'Neil 96], then describe LevelDB

We will discuss:

- **Compaction** strategies
- Notable “tweaks” to the data structure
- Commonly cited drawbacks
- Potential applications

[O'Neil, Cheng, Gawlick '96]

An LSM-tree comprises a hierarchy of trees of increasing size

- All data inserted into in-memory tree (C_0)
- Larger on disk trees ($C_{i>0}$) hold data that does not fit into memory

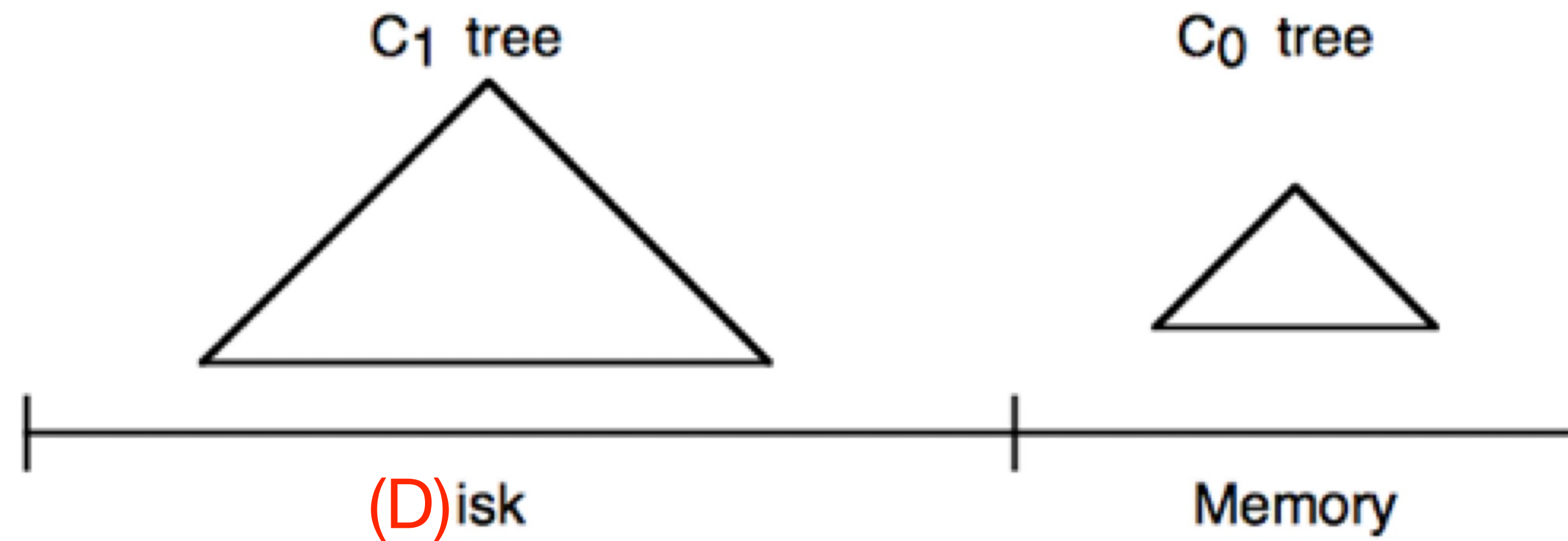

Figure 2.1. Schematic picture of an LSM-tree of two components

[O'Neil, Cheng, Gawlick '96]

When a tree exceeds its size limit, its data is merged and rewritten

- Higher level is always merged into next lower level (C_i merged with C_{i+1})
 - ▶ Merging always proceeds top down

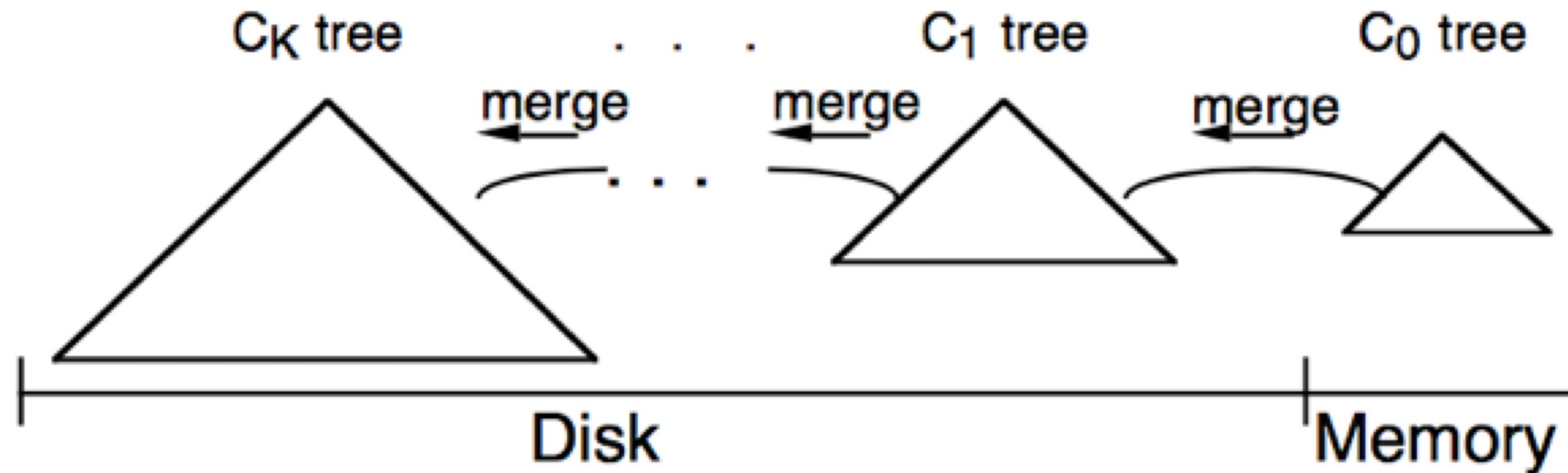

Figure 3.1. An LSM-tree of $K+1$ components

[O'Neil, Cheng, Gawlick '96]

- Recall mergesort from data structures/algorithms
 - ▶ We can efficiently merge two sorted structures in linear time using iterators
- When merging two levels, newer key-value pair versions replace older (GC)
 - ▶ LSM-tree **invariant**: newest version of any key-value pair is version nearest to top of LSM-tree

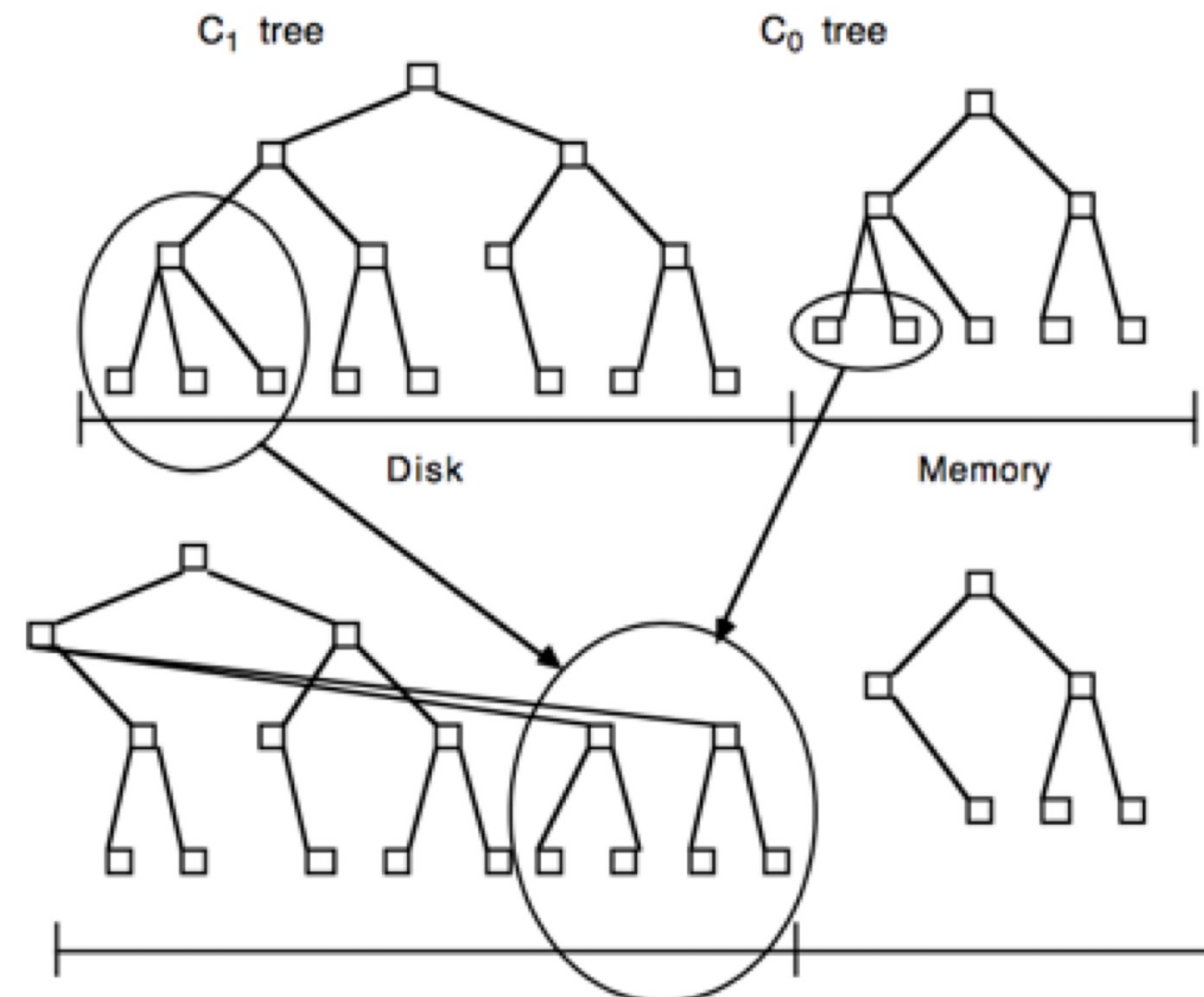

Figure 2.2. Conceptual picture of rolling merge steps, with result written back to disk

LSM-trees implement the dictionary interface

Maintain a set of key-value pairs (kv pairs)

- Support the following operations (at minimum):
 - ▶ $\text{insert}(k, v)$ - insert a new kv pair, (possibly) replacing old value
 - ▶ $\text{delete}(k)$ - remove all values associated with key k
 - ▶ $(k, v) = \text{query}(k)$ - return latest value v associated with key k
 - ▶ $\{(k_1, v_1), (k_2, v_2), \dots, (k_j, v_j)\} = \text{query}(k_i, k_l)$ - return all key-value pairs in the range from k_i to k_l

> **Question:** How do we implement each of these operations?

Insert(k)

We insert the key-value pair into the in-memory level, C_0

- Don't care about lower levels, as long as newest version is one closest to top
- But if an old version of kv-pair exists in the top level, we must replace it
- If inserting into C_0 causes C_0 to exceed its size limit, compact (merge)

> Inserts are fast! Only touch C_0 in common case.

Delete(k)

We insert a **tombstone** into the in-memory level, C_0

- A tombstone is a “logical delete” of all key-value pairs with key k
 - ▶ When we merge a tombstone with a key-value pair, we delete the key-value pair
 - ▶ When we merge a tombstone with a tombstone, just keep one copy
 - ▶ When can we delete a tombstone?
 - ▶ At the lowest level
 - ▶ When merging a *newer* key-value pair with key k

> Deletes are fast! Only touch C_0 .

Query(k)

Begin our search in the in-memory level, C_0

- Continue until:
 - ▶ We find a key-value pair with key k (return that value)
 - ▶ We find a tombstone with key k (return “not found”)
 - ▶ We reach the lowest level and fail-to-find (return “not found”)

> Searches traverse (worst case) every level in the LSM-tree

Query(k_j, k_l)

We must search *every* level, $C_0 \dots C_n$

- Return all keys in range, taking care to:
 - ▶ Return newest (k_i, v_i) where $k_j < k_i < k_l$ such that there are no tombstones with key k_i that are newer than (k_i, v_i)
 - ▶ Common strategy is to create an iterator for each level and use merge-esque logic

> Range queries must scan every level in the LSM-tree (although not all ranges in every level)

LevelDB

Google's Open Source *LSM-tree-ish* KV-store

Some Definitions

LevelDB consists of a hierarchy of **SSTables**

- An SSTable is a sorted set of key-value pairs (Sorted Strings Table)
 - ▶ Typical SSTable size is 2MiB

The **growth factor** describes how the size of each level scales

- Let F be the growth factor (fanout)
- Let M be the size of the first level (e.g., 10MiB)
- Then the i^{th} level, C_i has size $F^i M$

The **spine** stores metadata about each level

- $\{\text{key}_i, \text{offset}_i\}$ for all SSTables in a level (plus other metadata TBD)
- Spine cached for fast searches of a given level
 - ▶ (if too big, a B-tree can be used to hold the spine for optimal searches)

LevelDB Example

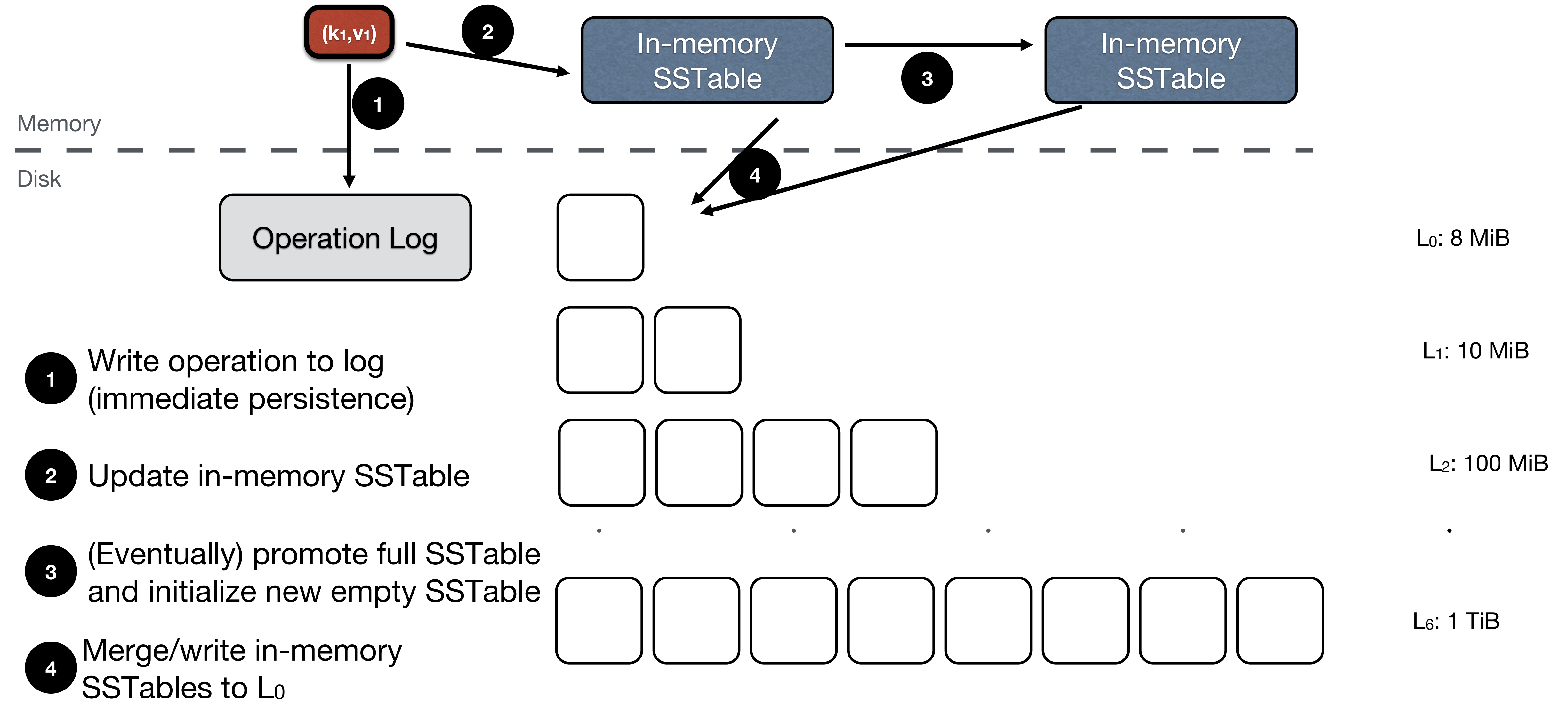

Compaction

How do we manage the levels of our LSM?

- **Ideal data management strategy would:**
 - ▶ Write all data sequentially for fast inserts
 - ▶ Keep all data sorted for fast searches
 - ▶ Minimize the number of levels we must search per query (low read amplification)
 - ▶ Minimize the number of times we write each key-value pair (low write amplification)
- **Good luck balancing so many competing interests in a single policy!**
 - ▶ ... but let's talk about some common approaches

Compaction Strategies

Option 1: Size-tiered

- Each “tier” is a collection SSTables with similar sizes
- When we compact, we merge some number of SSTables with the same size to create an SSTable in the next tier

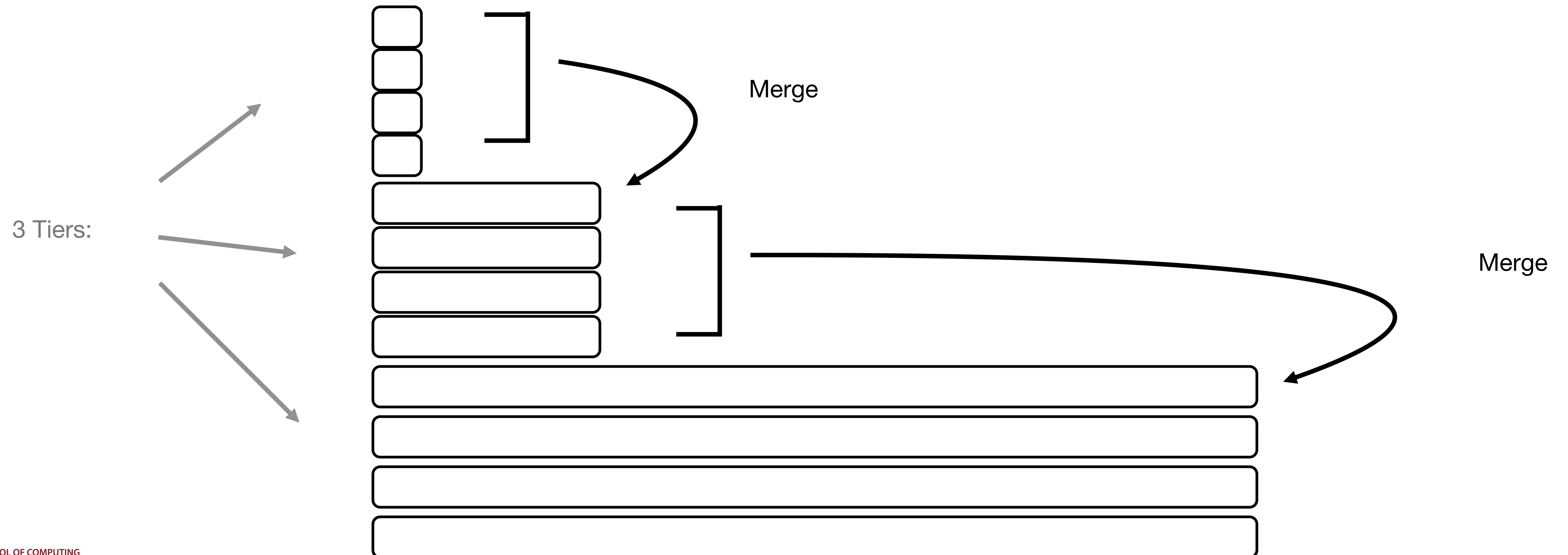

Compaction Strategies

Option 2: Level-tiered

- All SSTables are fixed size
- Each level is a collection SSTables with **non-overlapping** key ranges
- To compact, pick SSTable(s) from L_i and merge them with SSTable(s) in L_{i+1}
 - ▶ Rewrite merged SSTables into L_{i+1} (redistributing key ranges if necessary)
 - ▶ Possibly continue (cascading merge) of L_{i+1} to L_{i+2}
 - ▶ Several ways to choose candidate SSTables for merge (e.g., round-robin or ChooseBest)
 - ▶ Possibly add invariants to our LSM to control merging (e.g., an SSTable at L_{i+1} can cover at most X SSTables at L_{i+1})

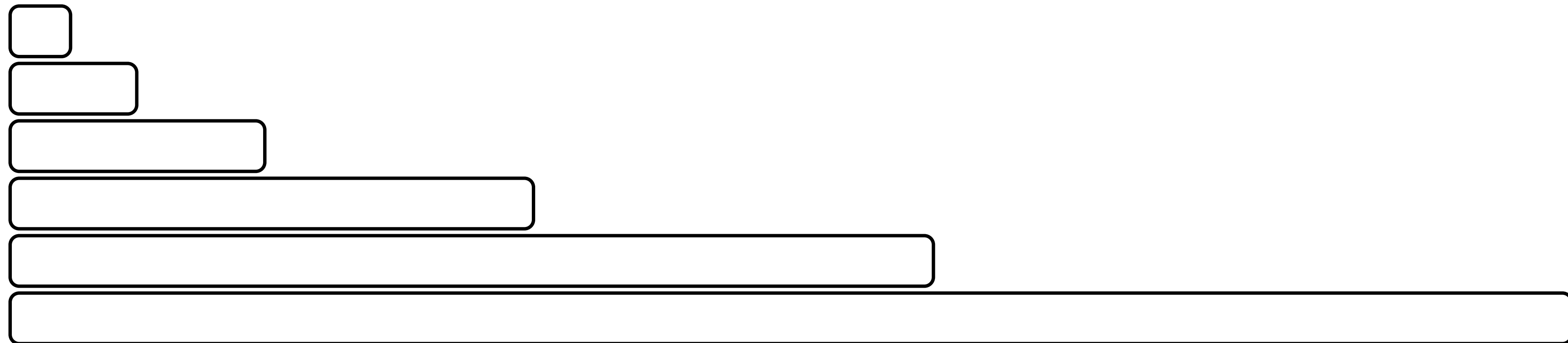

(Note: This picture shows the aggregate size of individual levels, not the size of individual SSTables in a level.)

LSM-tree Problems?

We write a lot of data during compaction

- Not all data is new
 - ▶ We may rewrite a key-value pair to the same level multiple times
- How might we save extra writes?
 - ▶ VT-trees [Shetty FAST '13]: if a long run of kv-pairs would be rewritten unchanged to the next level, instead write a pointer
- Problems with VT-trees?
 - ▶ Fragmentation
 - ▶ Scanning a level might mean jumping up and down the tree, following pointers

> There is a tension between locality and rewriting

LSM-tree Problems?

We write a lot of data during compaction

- Not all data written during a compaction is new data at that level
 - ▶ We may rewrite a key-value pair to the same level multiple times
- How might we save extra writes?
 - ▶ Fragmented LSM-Tree [Raju SOSP '17]: each level can contain up to F fragments
 - ▶ Fragments can be appended to a level without merging with SSTables in that level
 - ▶ Saves the work of doing a “merge” until there is enough work to justify the I/Os
- Problems with fragments?
 - ▶ Fragments can have overlapping key ranges, so may need to search through multiple fragments
 - ▶ Need to be careful about returning newest values

> Again, we see a tension between locality and rewriting

LSM-tree Problems?

We read a lot of data during searches

- We may need to search every level of our LSM-tree
 - ▶ Caching the spine & binary search both help (SSTables are sorted), but still many I/Os in worst case
- How might we save extra reads?
 - ▶ Bloom filters!
 - ▶ By adding a Bloom filter, we only search if the data exists in that level (or false positive)
 - ▶ Bloom filters for large data sets can fit into memory, so approximately $1+e$ I/Os per query
- Problems with Bloom filters?
 - ▶ Do they help with range queries?
 - ▶ Not really...

Thought Questions

How might you design:

- an LSM-tree for an SSD?
- an LSM-tree for a HDD?
 - ▶ how would your designs be different?
 - ▶ Different concerns (e.g., wear leveling & endurance, parallelism, gap between sequential and random I/O)

Should we store the data inside the index, or separating the data from the index (clustered vs. declustered index)

- How might you design a system that separates keys from values?
 - ▶ Wisckey [Lu FAST 16]: Store keys in LSM-tree, values in a log
- What are the advantages/disadvantages?
 - ▶ Can fit most of the LSM-tree (keys) in memory -> 1 I/O per search
 - ▶ Need to GC your value log, just like LFS

Final Thoughts

LSM-trees are a write-optimized data structure:

- Many updates are batched and committed in a sequential I/O

Although we may need to search for data in multiple levels, we can avoid unnecessary I/Os with additional metadata

- Bloom filters help avoid unnecessary searches in a given level
- Metadata in “spine” helps to target searches within a level

I/O amplification is one of the biggest challenges for LSM-trees

- **Leveled-design causes read amplification**
 - ▶ Searches may require I/Os at each level in worst case
- **Compaction causes write amplification**
 - ▶ Different compaction strategies favor write vs. read performance