

Knit: Component Composition for Systems Software

Alastair Reid, Matthew Flatt, Leigh
Stoller, Jay Lepreau, Eric Eide

University of Utah

Why Components?

- Everyone is writing too much code
 - ◆ Not enough code reuse
 - ◆ Hard to reconfigure
 - ◆ Hard to understand
 - ◆ Hard to test/verify
- Exceptions: Click, Scout, Ensemble, Fox, MMLite, OSKit, ...

Why Not Components?

- Overhead
 - ◆ Runtime
 - ◆ Programmer time
- Advanced systems don't work with C
- Complex component interdependencies
 - ◆ Locking restrictions
 - ◆ Top/bottom-half
 - ◆ Bootstrap sequence

Goal of Knit Project

To make components practical
for systems programming

Key to Achieving Goal

Static configuration language

- ◆ Enables error detection
- ◆ Enables optimization

Target#1: The Utah OSKit [SOSP'97]

- Approximately 500 components:
Device drivers, bootstrap code, TCP/IP stacks, filesystems, SNMP, etc.
- Doesn't impose architecture
- 10^6 lines of code from Linux, FreeBSD, NetBSD, Mach, Fluke, etc.

Outline

- Introduction
- The Knit component model
 - ◆ Atomic units
 - ◆ Compound units
 - ◆ Automatic Initialization
 - ◆ Detecting Configuration Errors
- Implementation and Performance
- Open issues

Atomic Units [PLDI'98]

<code>serve_cgi</code>	<code>serve_file</code>
<pre>int serve_web(...) { if (...) serve_cgi (...); else serve_file (...); }</pre>	<ul style="list-style-type: none">- <code>Ioskit</code>- <code>DKERNEL</code>- <code>DHAVE_CONFIG</code>
<code>serve_web</code>	

Compound Units [PLDI'98]

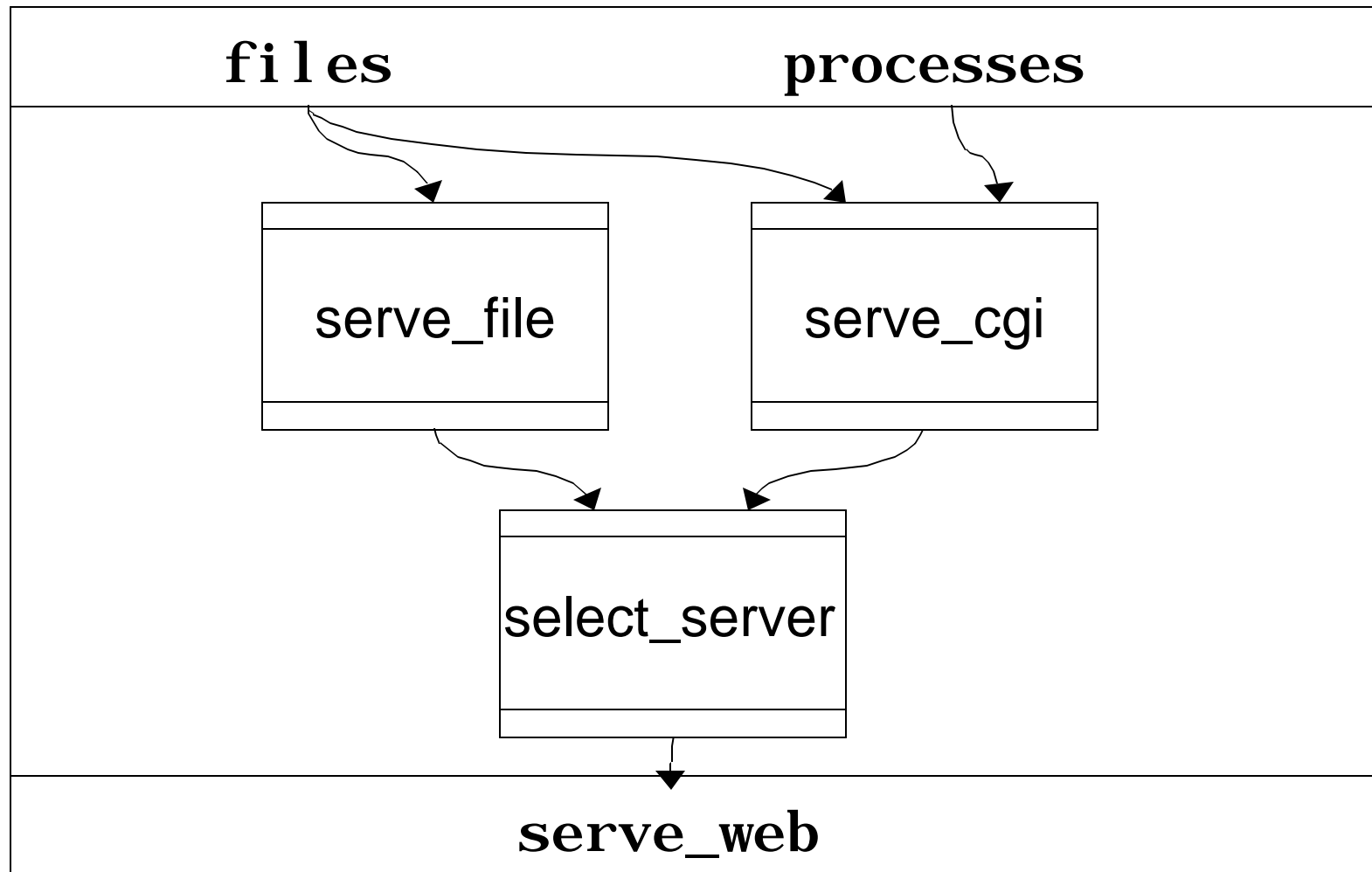

Initialization

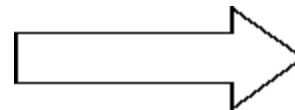
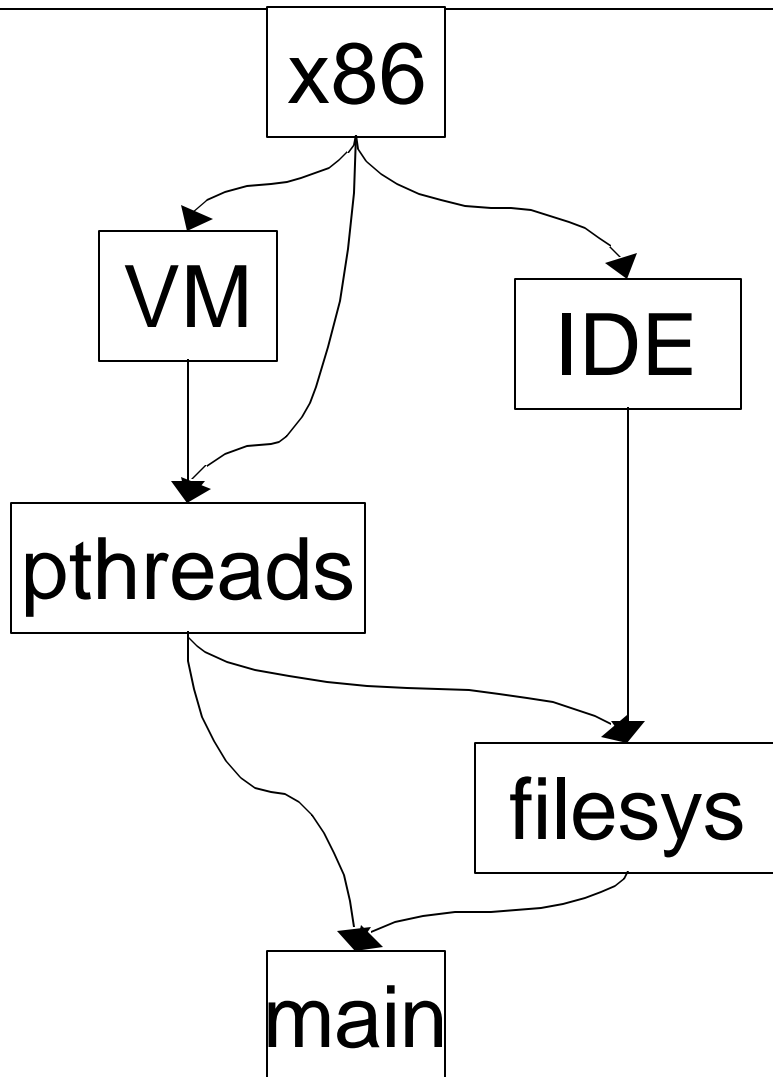

```
init_x86();  
init_IDE();  
init_VM();  
init_threads();  
init_filesys();  
init_main();
```

Initialization

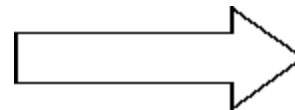
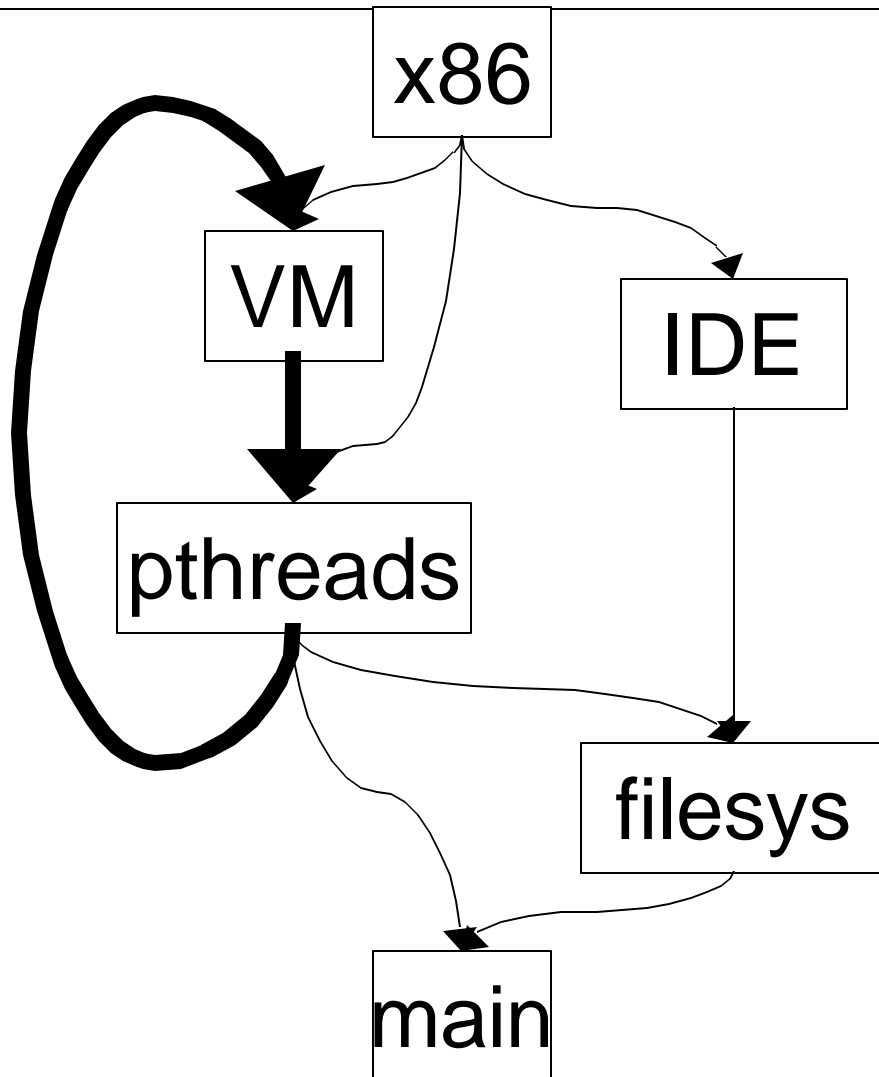

```
init_x86();  
init_IDE();  
init_VM();  
init_pthreads();  
init_filesys();  
init_main();
```

When Can We Break Cycles?

1. Component 'contains' subcomponents

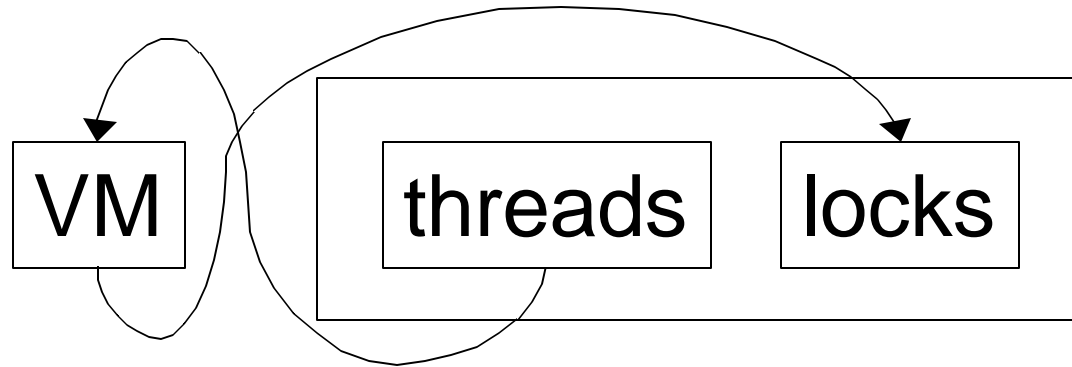

2. No dependency between initializers

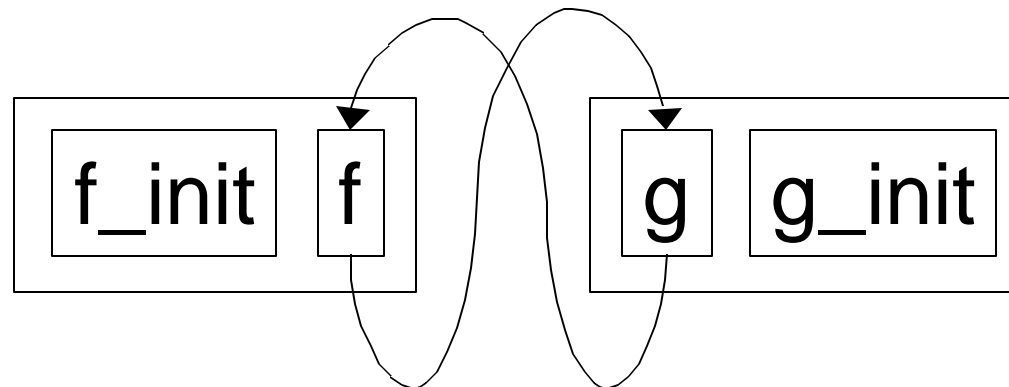

Automatic Initialization

- Knit generates initialization sequence
- Cycles are resolved by refining initialization dependencies in units
- Experience
 - ◆ 5% of units need dependencies refined
 - ◆ Programmers find initialization a big win

Detecting Composition Errors

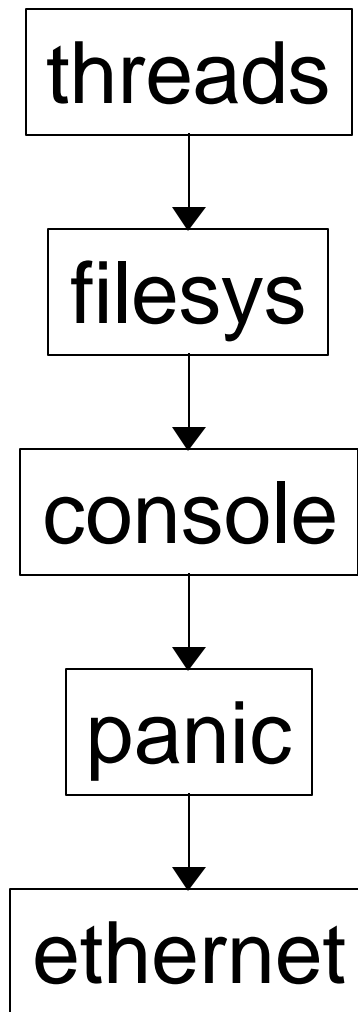

Detecting Composition Errors

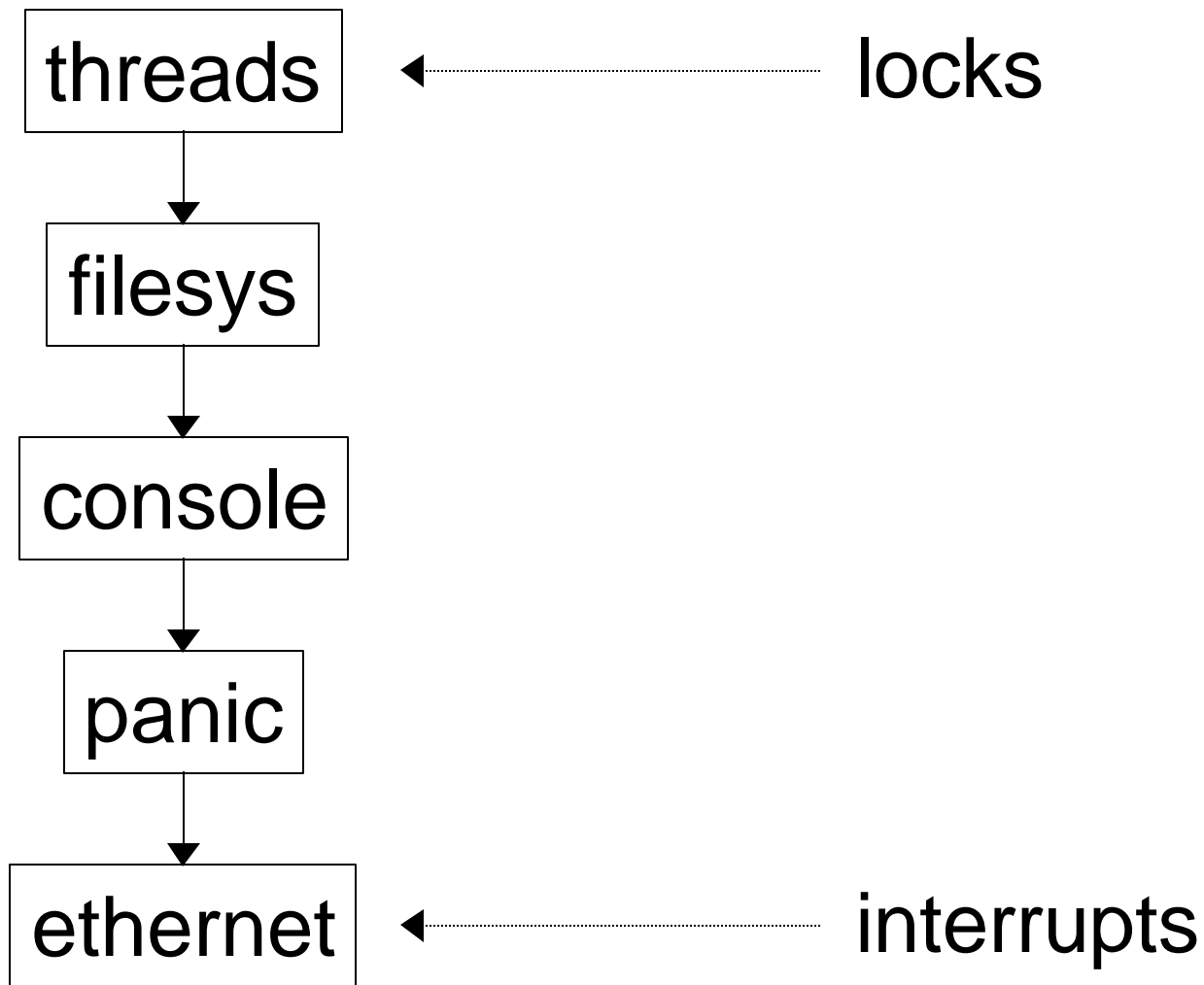

Detecting Composition Errors

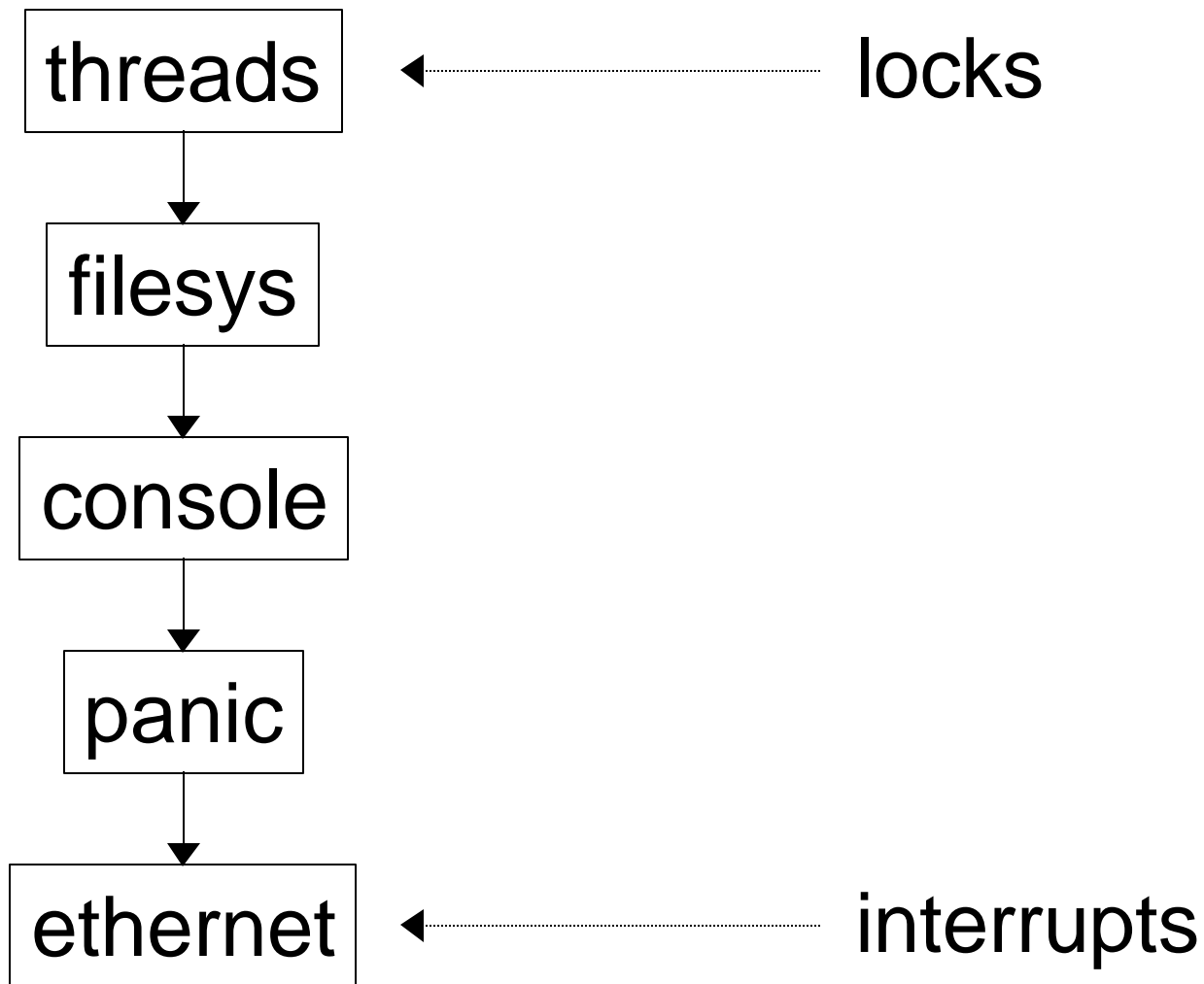

Detecting Composition Errors

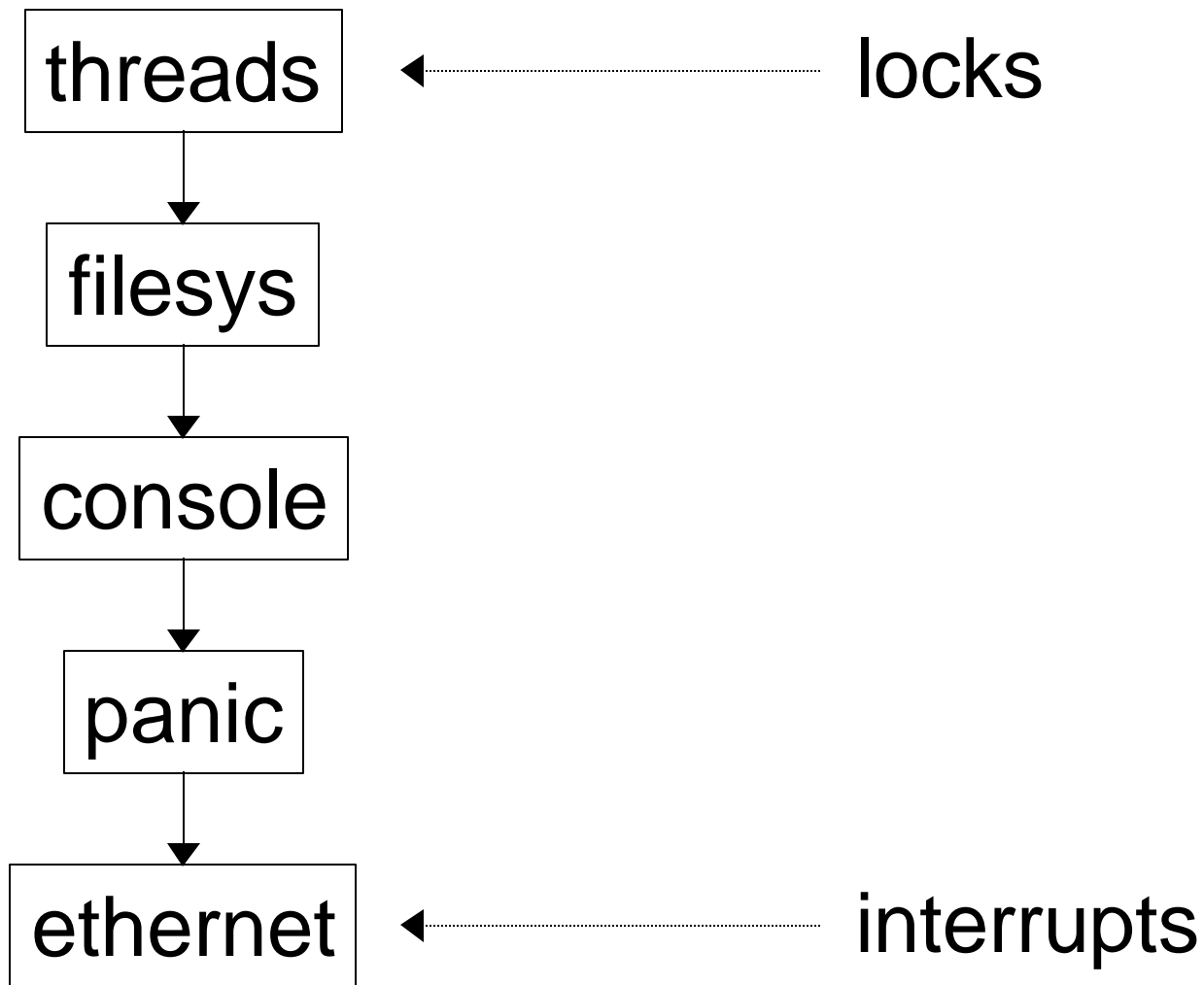

Detecting Composition Errors

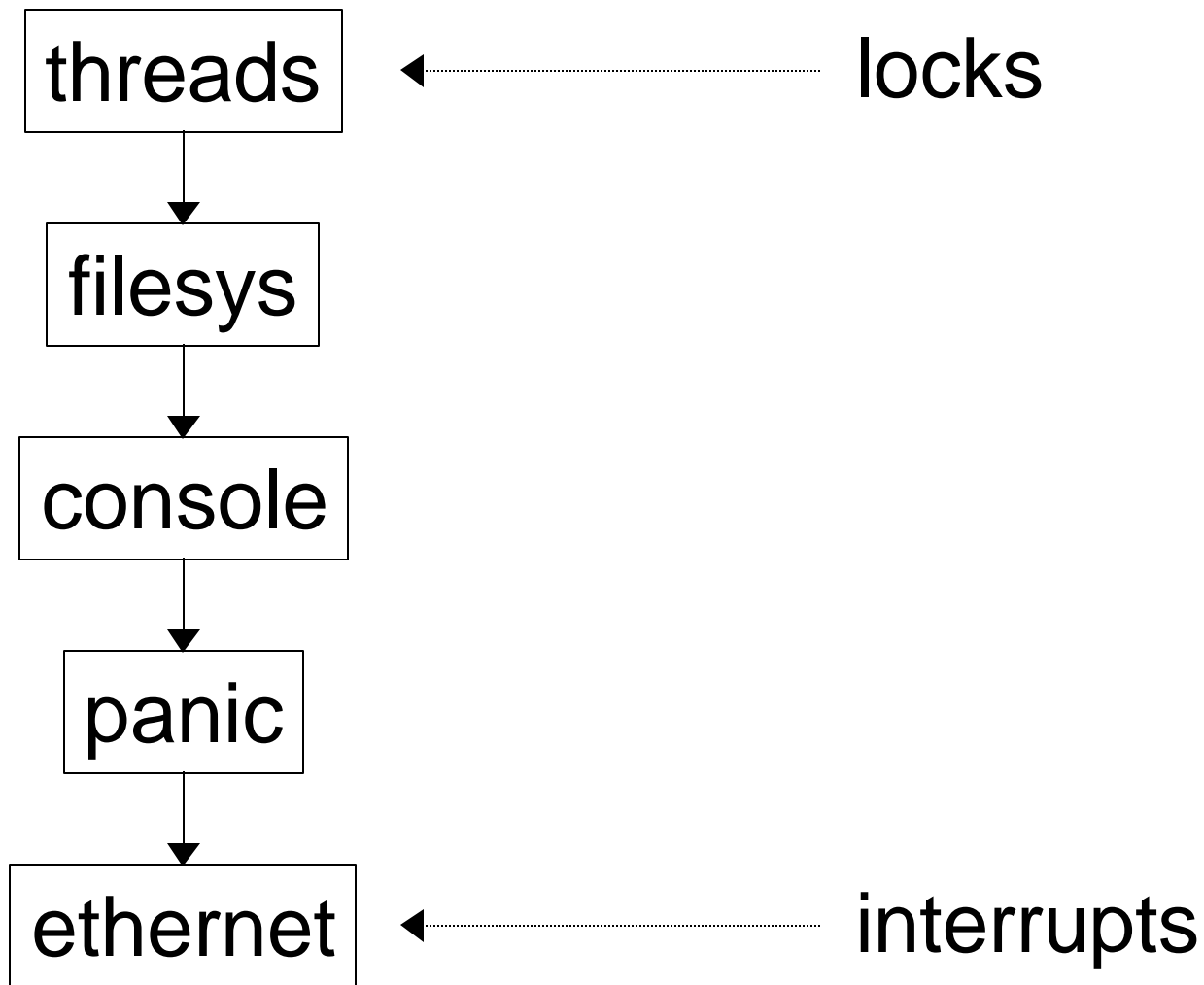

Detecting Composition Errors

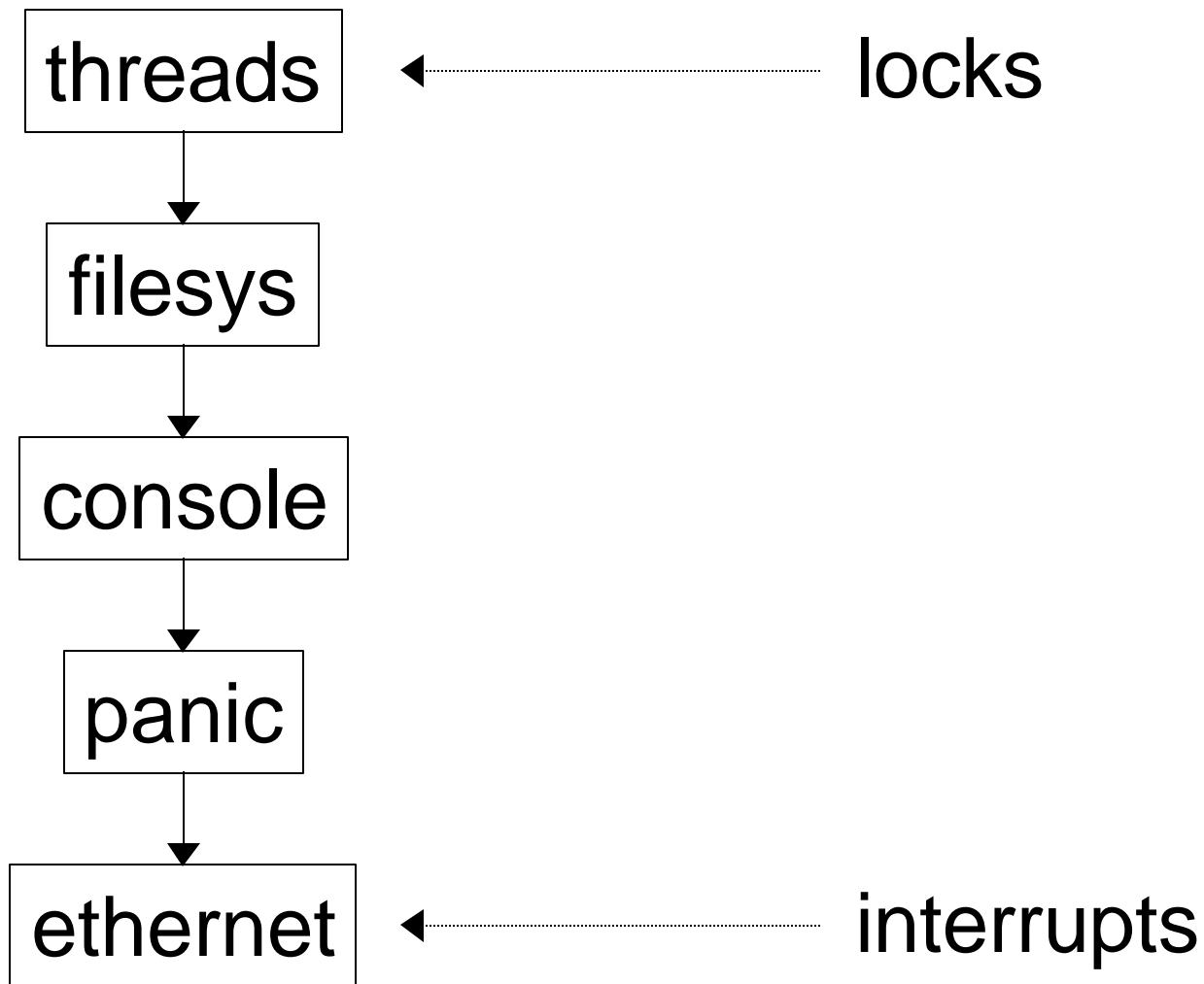

Detecting Composition Errors

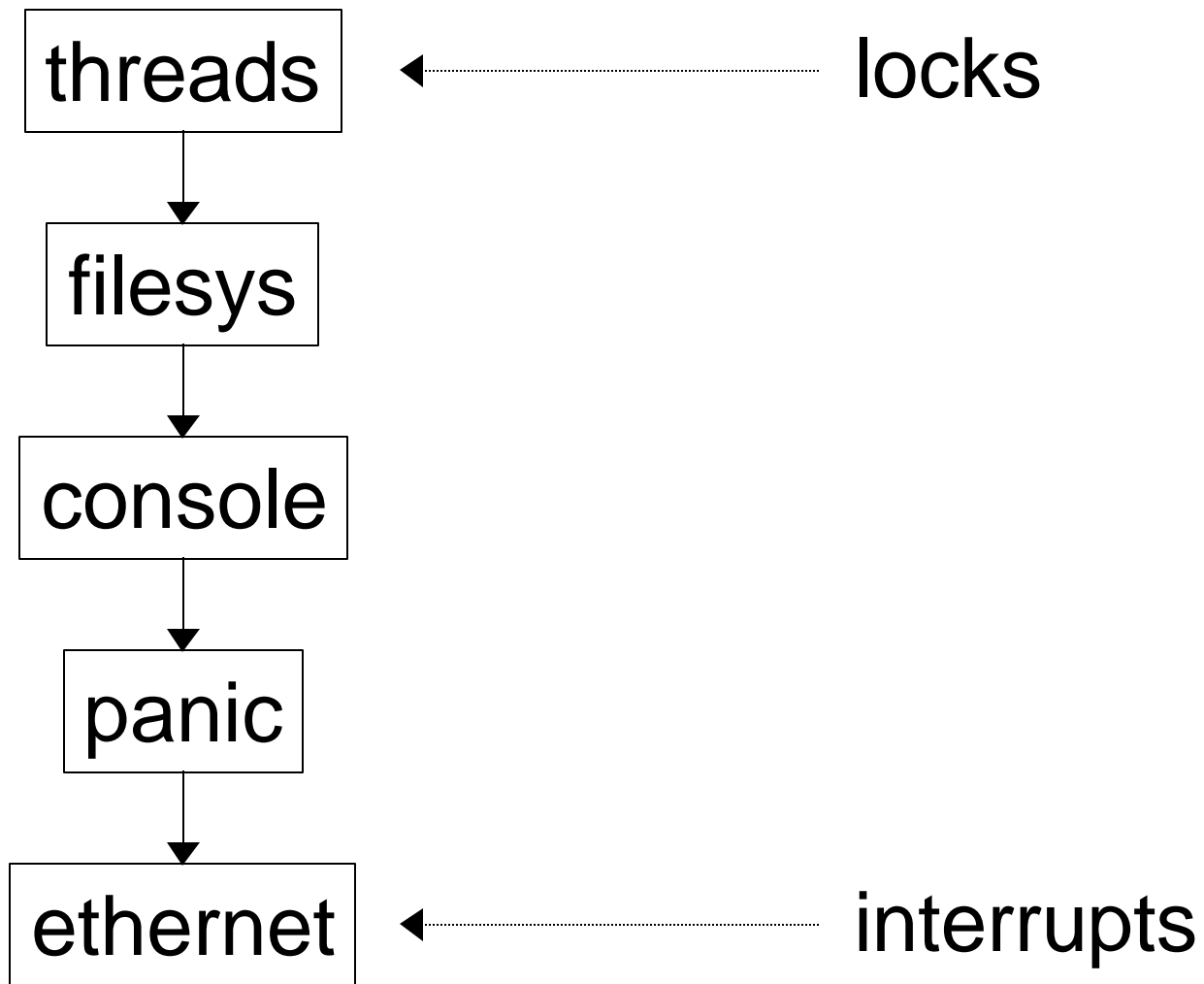

Detecting Composition Errors

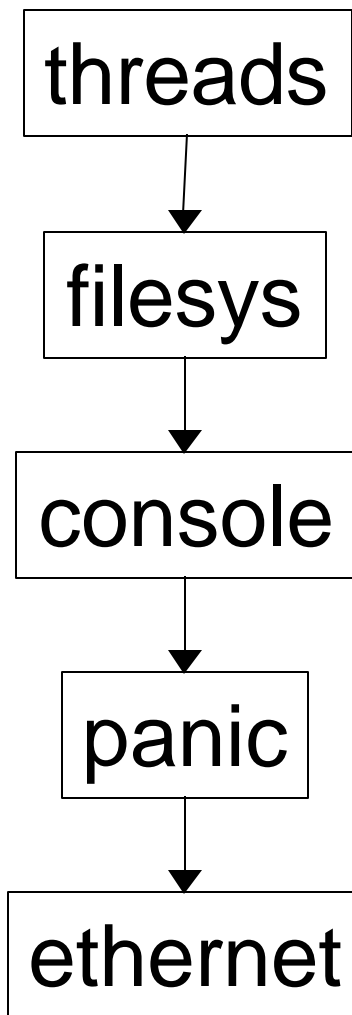

`context(threads) <= ProcessContext`

`context(filesys) <= context(threads)`

`context(console) <= context(filesys)`

`context(panic) <= context(console)`

`NoContext <= context(ethernet)`

`ProcessContext < NoContext`

Extensible Constraint System

- Constraint system propagates properties through component interconnections
 - ◆ Knit can detect global errors
- Constraint system is extensible
 - ◆ In context X, don't do Y
 - ◆ Type system for Modular IP Routers (e.g., Click)
 - ◆ ...

Knit

- Supports C, assembly and object files
- Separates interconnections from code
- Automatic initialization
- Extensible constraint system
- Allows cyclic component dependencies
- Allows multiple instances of components
- Text based

Outline

- Introduction
- The Knit component model
- Implementation and Performance
- Open issues

Implementation (Unoptimized)

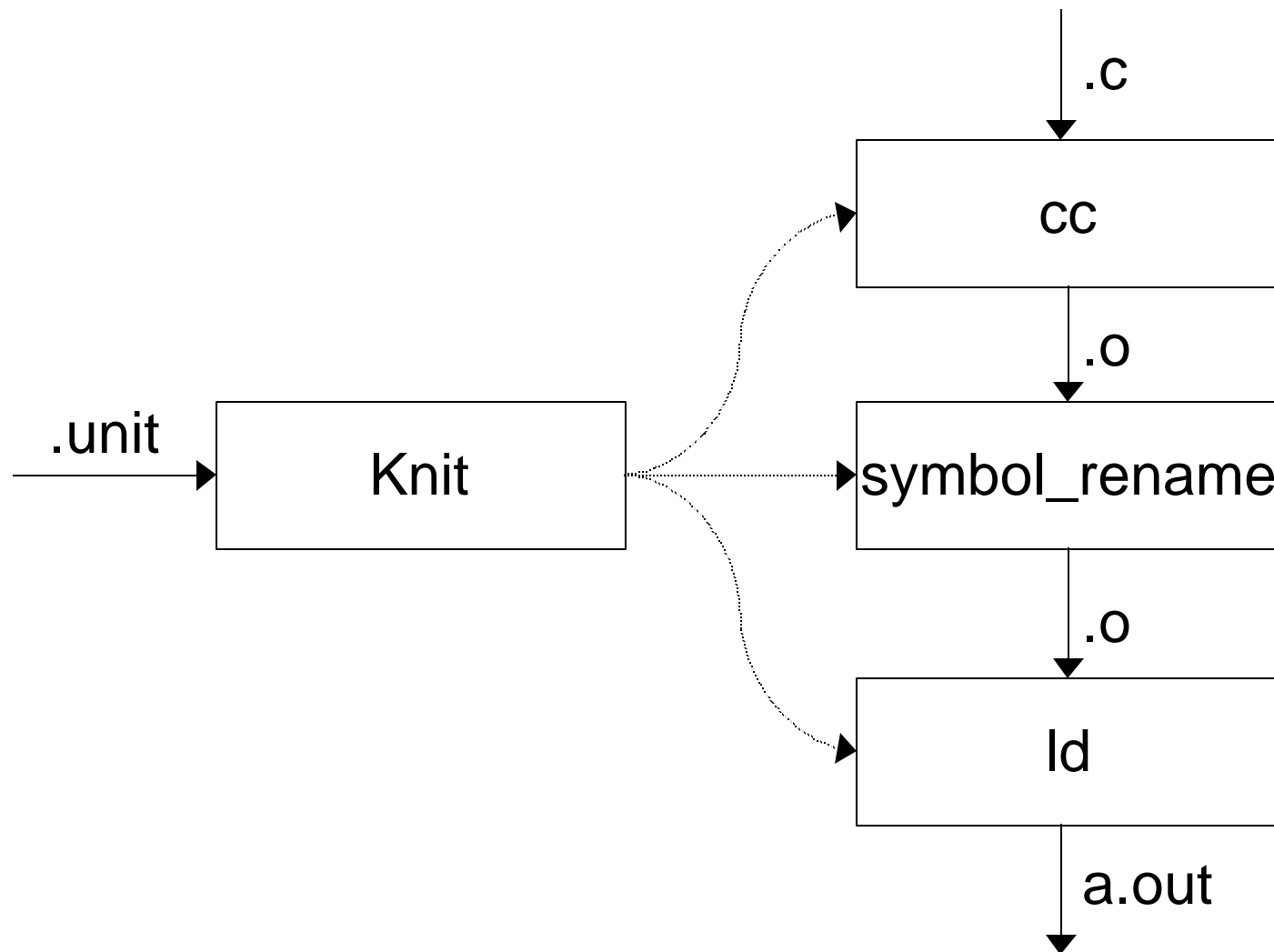

Performance

- Component cost should not distort system structure
- Reduce overhead by eliminating function calls

Click and Clack

- Click modular network router from MIT [SOSP'99]
- Clack
 - ◆ Re-implementation of Click using Knit
 - ◆ Similar performance to Click
- Many small components

Performance of Clack

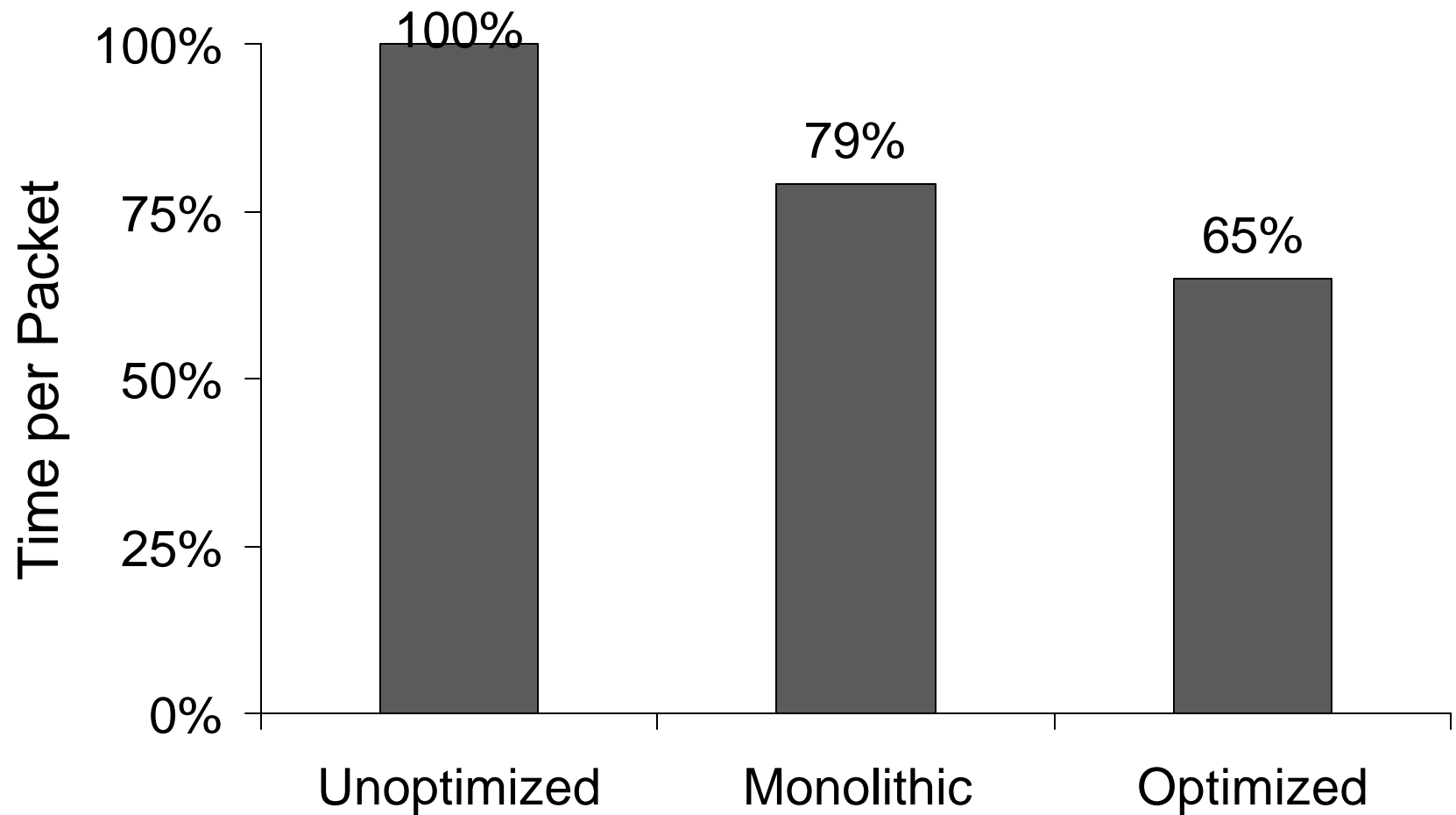

Open Issues

- Is Knit general purpose?
 - ◆ Need more users
 - ◆ Need more applications
- Is the constraint system extensible enough?
- Implicit linking vs. explicit linking?

Conclusions

- State of the art component system for C
- Targeted at systems code
 - ◆ Automatic initialization
 - ◆ Detects local and global errors
 - ◆ Low performance overhead
- Available ASAP: <http://www.cs.utah.edu/flux/>